

2

LENGTH MEASURING INSTRUMENTS

VERNIER CALIPER

MICROMETER

Vernier scale

A vernier scale lets one read more precisely from an evenly divided straight or circular measurement scale. It is fitted with a sliding secondary scale that is used to indicate where the measurement lies when it is in-between two of the marks on the main scale.

It was invented in its modern form in 1631 by the French mathematician Pierre Vernier (1580–1637). In some languages, this device is called a nonius, which is the latin name of the Portuguese astronomer and mathematician Pedro Nunes (1492–1578) who invented the principle.

When a measurement is taken by mechanical means using one of the above-mentioned instruments, the measure is read off a finely marked data scale (the "fixed" scale, in the diagram). The measure taken will usually be between two of the smallest gradations on this scale. The indicating scale ("vernier" in the diagram) is used to provide an even finer additional level of precision without resorting to estimation.

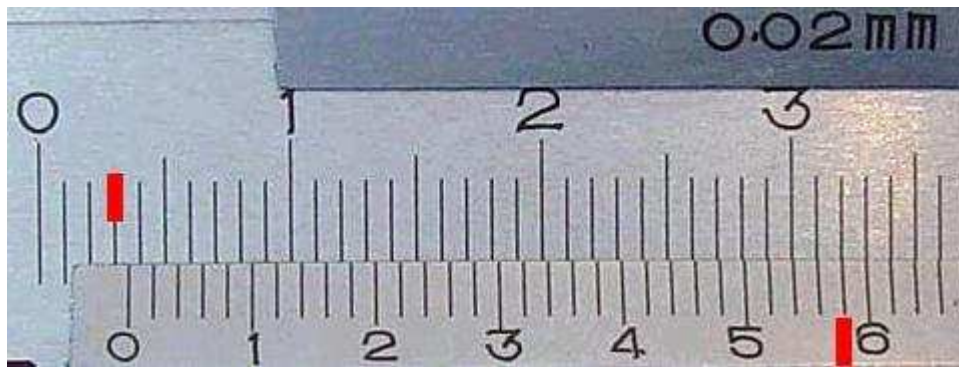

An enlarged view of the above calipers shows they have an accuracy of 0.02 mm. The reading is 3.58 mm. The 3 mm is read off from the upper (fixed) data scale. The 0.58 mm is obtained from the lower (sliding) indicating scale at the point of closest alignment between the two scales. The superimposed red markings show where the readings are taken.

The vernier scale is constructed so that it is spaced at a constant fraction of the fixed main scale. So for a decimal measuring device each mark on the vernier would be spaced nine tenths of those on the main scale. If you put the two scales together with zero points aligned then the first mark will be one tenth short of the main scale mark, the second two tenths short and so on up to the ninth mark which would be misaligned by nine tenths. Only when a full ten marks have been counted would there be an alignment because the tenth mark would be ten tenths, that is a whole main scale unit, short and will therefore align with the ninth mark on the main scale.

Now if you move the vernier by a small amount say one tenth of its fixed main scale, the only pair of marks which come into alignment will be the first pair since these were the only ones originally misaligned by one tenth. If we had moved it 2 tenths then the second pair and only the second would be in alignment since these are the only ones which were originally misaligned by that amount. If we had moved it 5 tenths then the fifth pair and only the fifth would be in alignment. And so on for any movement, only one pair of marks will be in alignment and that pair will show what is the value of the small displacement.

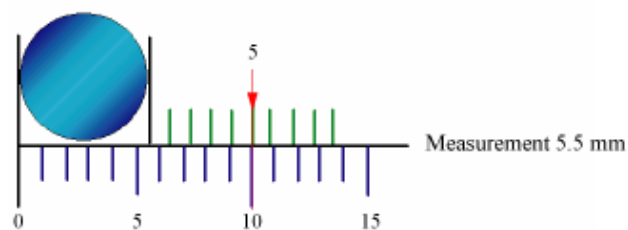
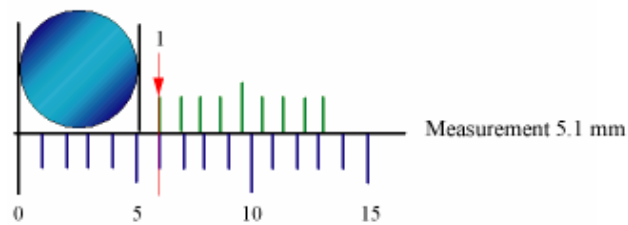
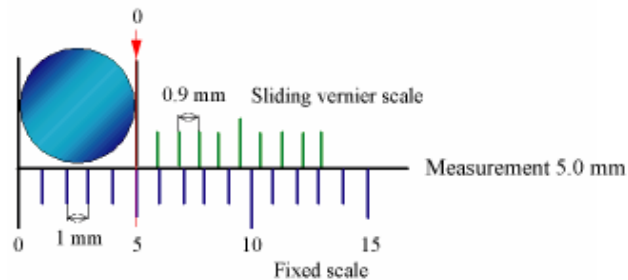
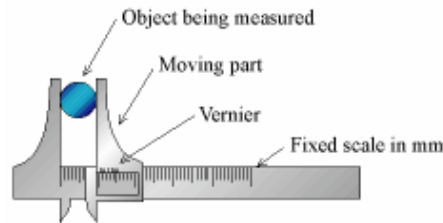

Caliper

A caliper is a device used to measure the distance between two symmetrically opposing sides. A caliper can be as simple as a compass with inward or outward-facing points. The tips of the caliper are adjusted to fit across the points to be measured, the caliper is then removed and the distance read by measuring between the tips with a measuring tool, such as a ruler.

Vernier Caliper

A variation to the more traditional caliper is the inclusion of a vernier scale, this makes it possible to directly obtain an accurate measurement. Vernier calipers can measure internal dimensions (using the uppermost jaws in the picture at right), external dimensions using the pictured lower jaws, and depending on the manufacturer, depth measurements by the use of a probe that is attached to the movable head and slides along the centre of the body. This probe is slender and can get into deep grooves that may prove difficult for other measuring tools. The vernier scales will often include both metric and imperial measurements on the upper and lower part of the scale. Vernier calipers commonly used in industry provide accuracy to a hundredth of a millimeter, or one thousandths of an inch. A more accurate instrument used for the same purpose is the micrometer.

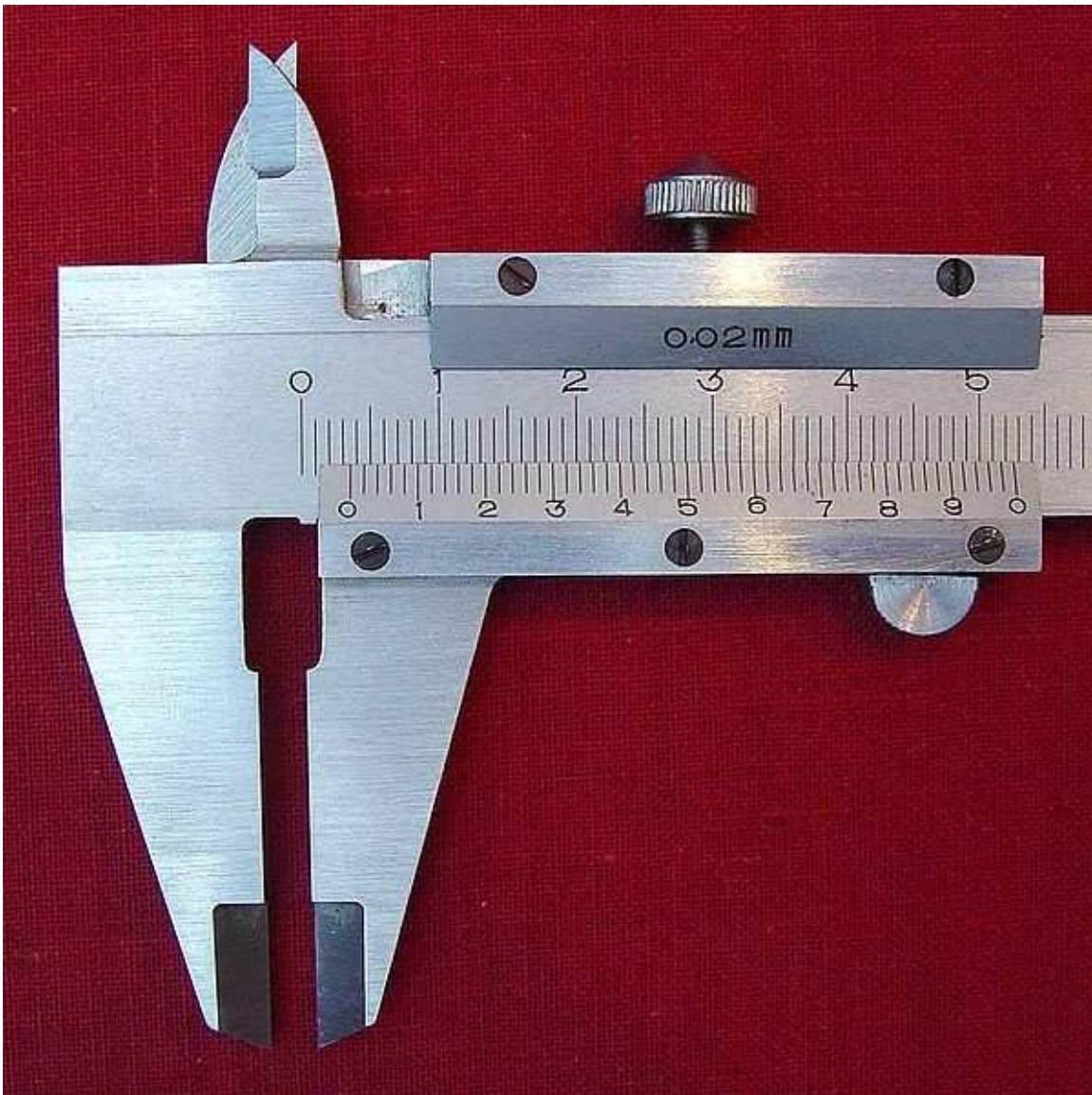

Digital Caliper

A refinement now popular is the replacement of the analog dial with an electronic digital display. This version of the caliper finally allows simply reading the value directly from a single display. Many digital calipers can also be switched between metric and English units and all provide for zeroing the display at any point along the slide, allowing the same sort of differential measurements as with the dial caliper but without the need to read numbers that may be upside down. Digital calipers may also contain some sort of "reading hold" feature, allowing the reading of dimensions even in very awkward locations where the display cannot be directly seen.



Micrometer

The micrometer is a precision measuring instrument, used by engineers. Each revolution of the ratchet moves the spindle face 0.5mm towards the anvil face. The object to be measured is placed between the anvil face and the spindle face. The ratchet is turned clockwise until the object is 'trapped' between these two surfaces and the ratchet makes a 'clicking' noise. This means that the ratchet cannot be tightened any more and the measurement can be read.

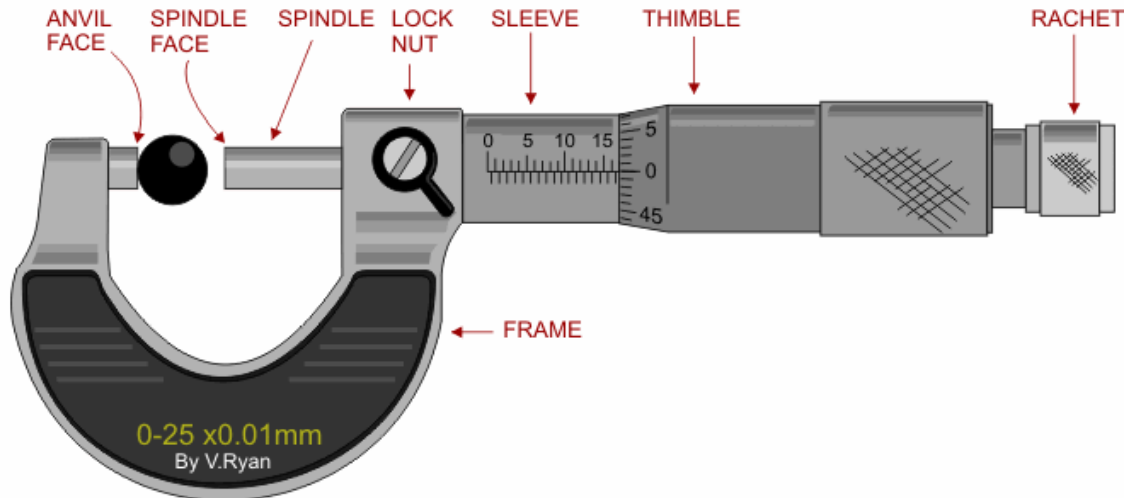

Reading an inch-system micrometer

The spindle of an inch-system micrometer has 40 threads per inch, so that one turn moves the spindle axially 0.025 inch ($1 \div 40 = 0.025$), equal to the distance between two graduations on the frame. The 25 graduations on the thimble allow the 0.025 inch to be further divided, so that turning the thimble through one division moves the spindle axially 0.001 inch ($0.025 \div 25 = 0.001$). To read a micrometer, count the number of whole divisions that are visible on the scale of the frame, multiply this number by 25 (the number of thousandths of an inch that each division represents) and add to the product the number of that division on the thimble, which coincides with the axial zero line on the frame. The result will be the diameter expressed in thousandths of an inch. As the numbers 1, 2, 3, etc., opposite every fourth sub-division on the frame, indicate hundreds of thousandths, the reading can easily be taken mentally.

Suppose the thimble were screwed out so that graduation 2, and three additional sub-divisions were visible (as shown in the image), and that graduation 1 on the thimble coincided with the axial line on the frame. The reading then would be $0.200 + 0.075 + 0.001$, or 0.276 inch.



Reading a metric micrometer

The spindle of an ordinary metric micrometer has 2 threads per millimeter, and thus one complete revolution moves the spindle through a distance of 0.5 millimeter. The longitudinal line on the frame is graduated with 1-millimeter divisions and 0.5-millimeter subdivisions. The thimble has 50 graduations, each being 0.01 millimeter (one-hundredth of a millimeter). To read a metric micrometer, note the number of millimeter divisions visible on the scale of the sleeve, and add the total to the particular division on the thimble, which coincides with the axial line on the sleeve.

Suppose that the thimble were screwed out so that graduation 5, and one additional 0.5 subdivisions were visible (as shown in the image), and that graduation 28 on the thimble coincided with the axial line on the sleeve. The reading then would be $5.00 + 0.5 + 0.28 = 5.78$ mm.



Reading a vernier micrometer

Some micrometers are provided with a vernier scale on the sleeve in addition to the regular graduations. These permit measurements within 0.001 millimeter to be made on metric micrometers, or 0.0001 inches on inch-system micrometers.

Metric micrometers of this type are read as follows: First determine the number of whole millimeters (if any) and the number of hundredths of a millimeter, as with an ordinary micrometer, and then find a line on the sleeve vernier scale which exactly coincides with one on the thimble. The number of this coinciding vernier line represents the number of thousandths of a millimeter to be added to the reading already obtained.

Thus, for example, a measurement of 5.783 millimeters would be obtained by reading 5.5 millimeters on the sleeve, and then adding 0.28 millimeter as determined by the thimble. The vernier would then be used to read the 0.003 (as shown in the image).

Inch micrometers are read in a similar fashion.

Note: 0.01 millimeter = 0.000393 inch, and 0.002 millimeter = 0.000078 inch (78 millionths). Therefore, metric micrometers provide smaller measuring increments than comparable inch unit micrometers—the smallest graduation of an ordinary inch-reading micrometer is 0.001 inch; the vernier type has graduations down to 0.0001 inch. When using a metric or inch micrometer, without a vernier, smaller readings than those graduated may of course be obtained by visual interpolation between graduations.

