



## Department of Mechanical Engineering

AMEE 202  
Introduction to Fluid Mechanics

Duration: 1/2 hour  
Lecturer: Marios M. Fyrillas

Student Name: .....

Registration Number: .....

### QUIZ (GROUP A)

#### Instructions to candidates:

Attempt all questions. Show all steps and explain the assumptions you take in order to solve a problem. Use the following constants if needed:

$$\rho_{\text{H}_2\text{O}} = 1000 \text{ kg/m}^3, \mu_{\text{H}_2\text{O}} = 1.15 \times 10^{-3} \text{ Pa} \cdot \text{s}, \rho_{\text{air}} = 1.225 \text{ kg/m}^3, \mu_{\text{air}} = 1.79 \times 10^{-5} \text{ kg/(m} \cdot \text{s)}$$

$$g = 9.81 \text{ m/s}^2, p_{\text{atm}} = 1.01 \times 10^5 \text{ N/m}^2, 1.0 \text{ in} = 0.0254 \text{ m.}$$

#### Question 1 (40 points)

Complete the following table

Property/ Quantity	Definition in Greek	Symbol	Units/definition	Equation
		$\rho$		
Reynolds number		Re		$\frac{\rho U D}{\mu}$
Torque				
			m/s	
Pressure	Πίεση			
			W, Watt	

**Question 2 (60 points)**

A piston with diameter  $D = 50 \text{ mm}$  and length  $l = 75 \text{ mm}$ , moves vertically in an open-ended lubricated cylinder with a radial clearance of  $b = 0.1 \text{ mm}$ . If the piston is moving downwards with a constant velocity of  $0.1 \text{ m/s}$  find:

- The lubricated area
- The velocity of the oil on the piston
- The velocity of the oil on the cylinder
- The x-sectional area of the cylinder

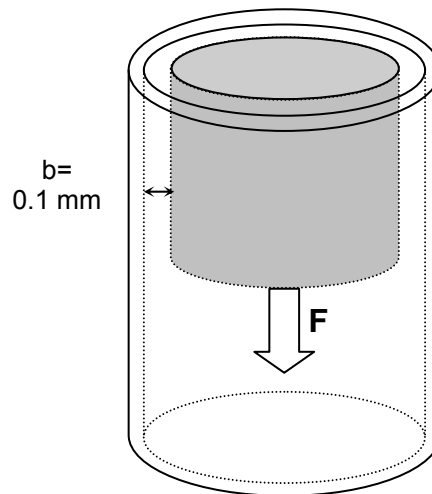



# FREDERICK UNIVERSITY CYPRUS

## Department of Mechanical Engineering

AMEE 202  
Introduction to Fluid Mechanics

Duration: 1/2 hour  
Lecturer: Marios M. Fyrillas

Student Name: .....

Registration Number: .....

### QUIZ (GROUP B)

#### Instructions to candidates:

Attempt all questions. Show all steps and explain the assumptions you take in order to solve a problem. Use the following constants if needed:

$$\rho_{H_2O} = 1000 \text{ kg/m}^3, \mu_{H_2O} = 1.15 \times 10^{-3} \text{ Pa} \cdot \text{s}, \rho_{air} = 1.225 \text{ kg/m}^3, \mu_{air} = 1.79 \times 10^{-5} \text{ kg/(m} \cdot \text{s)}$$

$$g = 9.81 \text{ m/s}^2, p_{atm} = 1.01 \times 10^5 \text{ N/m}^2, 1.0 \text{ in} = 0.0254 \text{ m}.$$

#### Question 1 (40 points)

Complete the following table

Property/ Quantity	Definition in Greek	Symbol	Units/definition	Equation
			m/s <sup>2</sup>	
Shear stress				
Reynolds number		Re		$\frac{\rho U D}{\mu}$
Torque				
			J, Joules	

**Question 2 (60 points)**

A piston with diameter  $D = 50 \text{ mm}$  and length  $l = 75 \text{ mm}$ , moves vertically in an open-ended lubricated cylinder with a radial clearance of  $b = 0.1 \text{ mm}$ . If the piston is moving downwards with a constant velocity of  $0.1 \text{ m/s}$  find:

- The lubricated area
- The velocity of the oil on the piston
- The x-sectional area of the piston

