



AMEE 202, ACEH 315
Introduction to Fluid Mechanics

Duration: 1/2 hour
Lecturer: Marios M. Fyrillas

Student Name:

Registration Number:

QUIZ (GROUP A)

Instructions to candidates:

Show all steps and explain the assumptions you take in order to solve a problem. Use the following constants if needed:

$$\rho_{H_2O} = 1000 \text{ kg/m}^3, \mu_{H_2O} = 1.15 \times 10^{-3} \text{ Pa} \cdot \text{s}, \rho_{air} = 1.225 \text{ kg/m}^3, \mu_{air} = 1.79 \times 10^{-5} \text{ kg/(m}\cdot\text{s)}$$
$$g = 9.81 \text{ m/s}^2, p_{atm} = 1.01 \times 10^5 \text{ N/m}^2, 1.0 \text{ in} = 0.0254 \text{ m}, 12 \text{ in} = 1 \text{ ft.}$$

A 18 kg, 0.25 m- diameter cylindrical tank slides slowly down a ramp with a constant speed of 0.03 m/s as shown in the Figure. The uniform-thickness oil layer on the ramp has a viscosity of $\mu = 9.0 \text{ Pa} \cdot \text{s}$. Determine the angle, θ , of the ramp.

Proceed as follows:

- Find the Shear Stress τ . **[20 points]**
- Find the Shear Force, i.e. "friction force". **[20 points]**
- Find the component of the weight in the direction of movement. **[20 points]**
- Equate the Shear Force found in (b) with the component of the weight found in (c). **[20 points]**
- Solve to find the angle θ . **[20 points]**

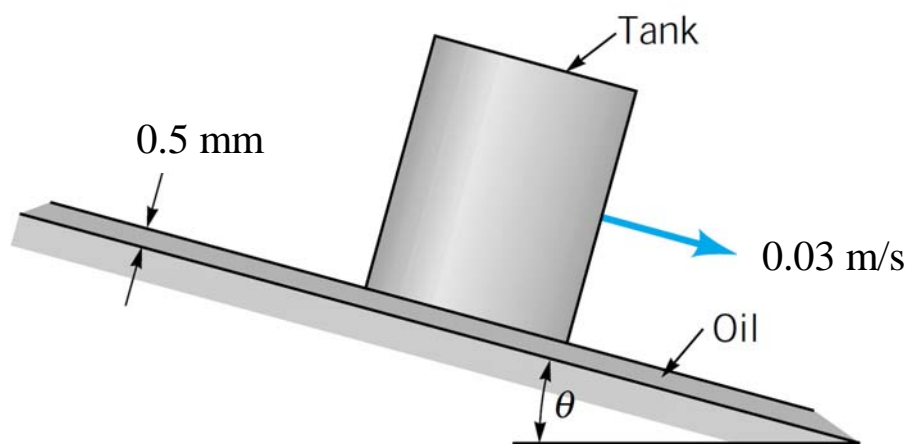



AMEE 202, ACEH 315
Introduction to Fluid Mechanics

Duration: 1/2 hour
Lecturer: Marios M. Fyrillas

Student Name:

Registration Number:

QUIZ (GROUP B)

Instructions to candidates:

Show all steps and explain the assumptions you take in order to solve a problem. Use the following constants if needed:

$$\rho_{H_2O} = 1000 \text{ kg/m}^3, \mu_{H_2O} = 1.15 \times 10^{-3} \text{ Pa} \cdot \text{s}, \rho_{air} = 1.225 \text{ kg/m}^3, \mu_{air} = 1.79 \times 10^{-5} \text{ kg/(m}\cdot\text{s)}$$

$$g = 9.81 \text{ m/s}^2, p_{atm} = 1.01 \times 10^5 \text{ N/m}^2, 1.0 \text{ in} = 0.0254 \text{ m}, 12 \text{ in} = 1 \text{ ft.}$$

QUESTION 1 [20 points]

The dynamic viscosity of a fluid is defined as $\nu = \frac{\mu}{\rho}$. Find its units.

QUESTION 2 [80 points]

A cylinder is sliding on a lubricated flat surface (see Figure). Determine the Shear Stress and the Shear Force as a function of the velocity U , the thickness of the oil-layer b , the viscosity μ and the diameter of the cylinder R .

